

*packard bell*

airFrame® 34" ULTRAWIDE CURVED  
GAMING MONITOR



M34000-J1  
User Guide

# In the Box



34" Monitor



Stand Arm

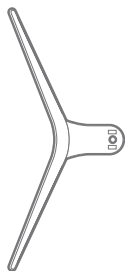

Stand Base



User Guide

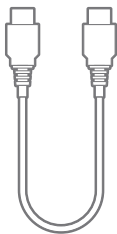

HDMI Cable

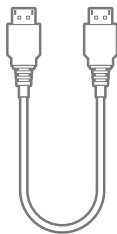

DP Cable

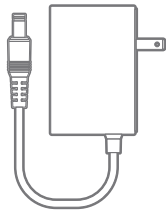

Power Adapter

# Buttons, Ports & Hardware

Monitor (front view)

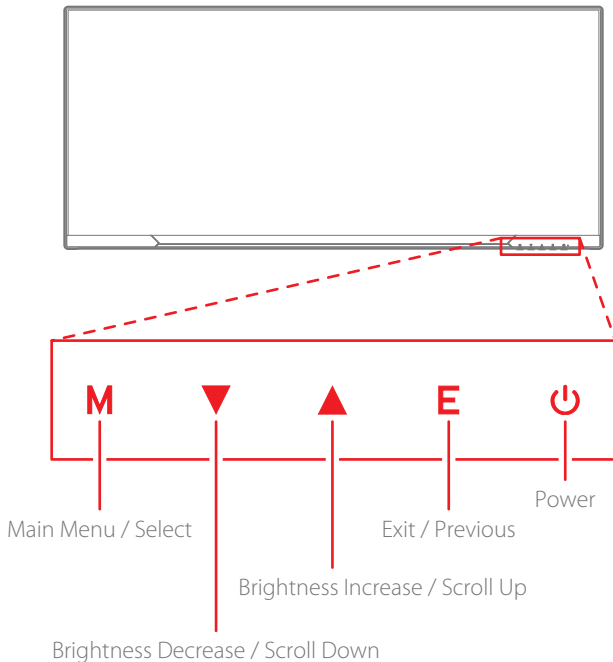

**NOTE:** To customize the monitor's settings, press the "M" button.

## Monitor (bottom view)

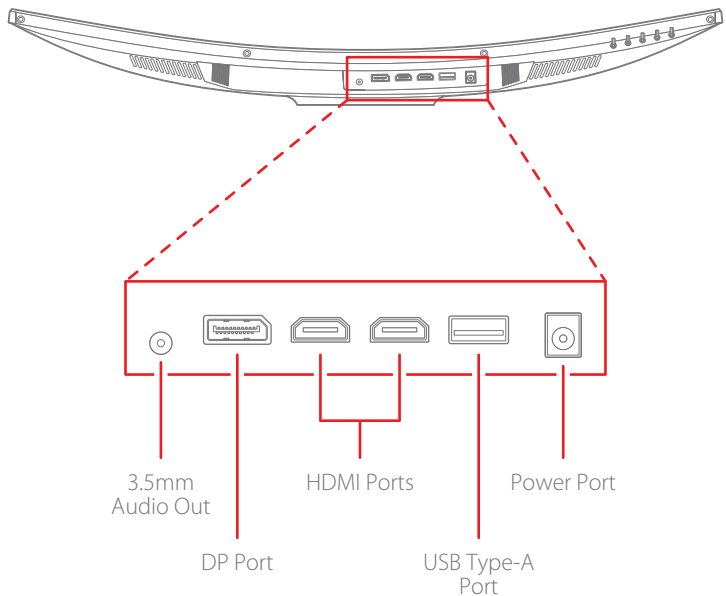

# Assembling the Monitor

1. Remove the screw from the stand arm.
2. Connect the stand base to the stand arm, then insert and tighten the screw as shown below.

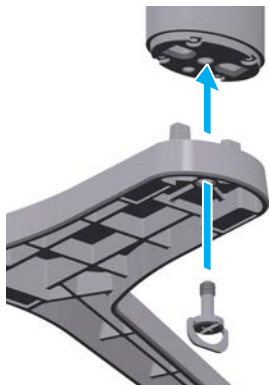
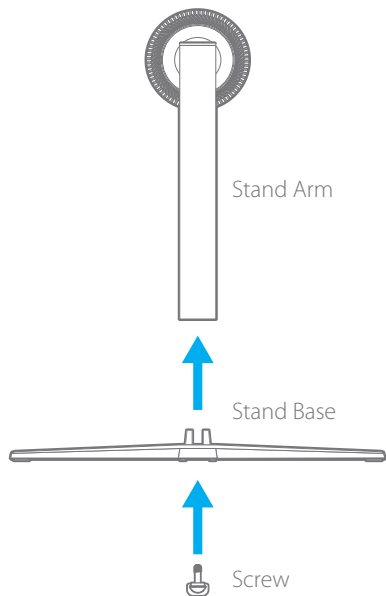

3. Insert and snap in the assembled stand to the monitor and make sure it is securely connected and locked into the monitor.

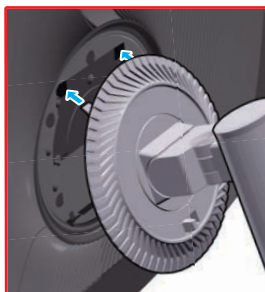

Insert and snap in the assembled stand to the monitor

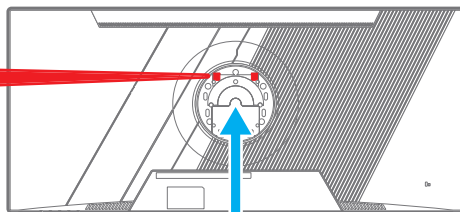

Monitor



You hear a click sound when the stand is securely locked into the monitor.



Slide and hold the lock switch to the right when you remove the stand from the monitor.

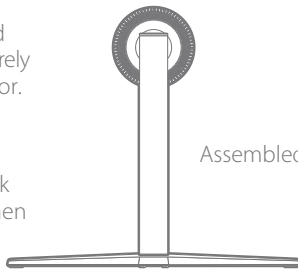

Assembled Stand

# Using the Monitor

Connect the power adapter to the monitor's power port and a wall outlet as shown below.

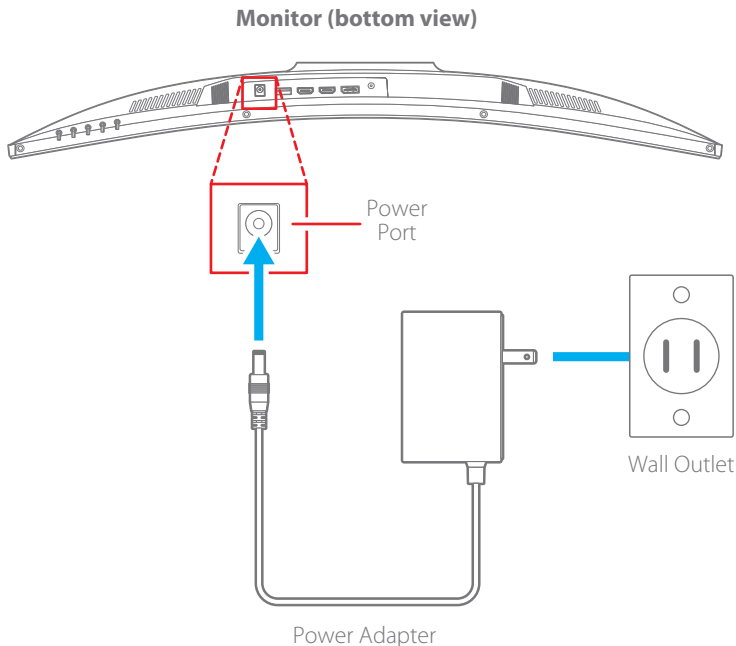

### Monitor (bottom view)

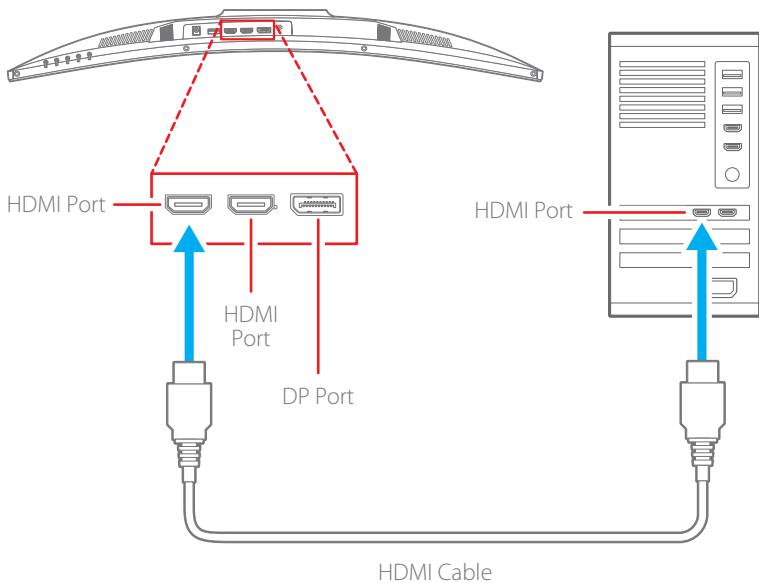

**NOTE:** To reach the maximum refresh rate of 165Hz, please use the DP port and included DP cable. Check if your hardware supports DP connection.



# Specifications & Legal Information

## Specifications:

- Display Size: 34" Ultra-Wide
- Resolution: 3440 x 1440
- Aspect Ratio: Widescreen 21:9
- Brightness (Typical): 300 cd/m<sup>2</sup>
- Response Time: 1ms
- Refresh Rate: Up to 165Hz
- Contrast (Typical): 4000:1
- Viewing Angle: 178°
- Curvature: 1800R
- Ports: HDMI (v2.0) x2, DP (v1.4), USB (Type A), 3.5mm Audio Out
- Compatibility: PC and Mac

## FCC Information

This device complies with Part 15 of the FCC Rules. Operation is subject to the following two conditions: (1) This device may not cause harmful interference, (2) This device must accept any interference received, including interference that may cause undesired operation.

## CAUTION

Changes or Modifications not expressly approved by the party responsible could void the user's authority to operate this device. This equipment has been tested and found to comply with the limits for a Class B digital device, pursuant to Part 15 of the FCC Rules. These limits are designed to provide reasonable protection against harmful interference in a residential installation. This equipment generates, uses and can radiate radio frequency energy and, if not installed and used in accordance with the instructions, may cause harmful interference to radio communications. However, there is no guarantee that interference will not occur in a particular installation. If this equipment does cause harmful interference to radio or television reception, which can be determined by turning the equipment off and on, the user is encouraged to try to correct the interference by one or more of the following measures:

- Reorient or relocate the receiving antenna.
- Increase the separation between the equipment and receiver.
- Connect the equipment into an outlet on a circuit different from that to which the receiver is connected.
- Consult the dealer or an experienced radio/TV technician for help.

## IC Statement

CAN ICES-003(B) / NMB-003(B)

This device contains licence-exempt transmitter(s)/receiver(s) that comply with Innovation, Science and Economic Development Canada's licence-exempt RSS(s). Operation is subject to the following two conditions:

1. This device may not cause interference.
2. This device must accept any interference, including interference that may cause undesired operation of the device.

# Limited Warranty

## 1 Year Limited Warranty

Territory: United States

### LIMITED WARRANTY TO ORIGINAL CONSUMER

This product as supplied and distributed new by an authorized retailer is warranted by Southern Telecom, Inc. to the original consumer purchaser against defects in materials and workmanship ("Warranty") as follows:

#### To obtain warranty service:

- Visit our customer support portal: [www.customersupport123.com](http://www.customersupport123.com) and select "Support".
- Select the brand, fill out the corresponding form (exchanges require dated proof of purchase from an authorized retailer) then submit your request.

Your product will be repaired or replaced, at our option, for the same or similar model of equal value if examination by the service center determines this product is defective. Products received damaged as a result of shipping will require you to file a claim with the carrier.

#### Warranty service not provided

This warranty does not cover damage resulting from accident, misuse, abuse, improper installation or operation, lack of reasonable care, unauthorized modification including software modifications such as the installation of custom firmware. This warranty is voided in the event any unauthorized person opens, alters or repairs this product. All products being returned to the authorized service center for repair must be suitably packaged.

NO WARRANTIES, WHETHER EXPRESS OR IMPLIED, INCLUDING, BUT NOT LIMITED TO, ANY IMPLIED WARRANTIES OF MERCHANTABILITY OR FITNESS FOR A PARTICULAR PURPOSE, OTHER THAN THOSE EXPRESSLY DESCRIBED ABOVE SHALL APPLY. DISTRIBUTOR FURTHER DISCLAIMS ALL WARRANTIES AFTER THE EXPRESS WARRANTY PERIOD STATED ABOVE. NO OTHER EXPRESS WARRANTY OR GUARANTY GIVEN BY ANY PERSON, FIRM OR ENTITY WITH RESPECT TO THE PRODUCT SHALL BE BINDING ON DISTRIBUTOR. REPAIR, REPLACEMENT, OR REFUND OF THE ORIGINAL PURCHASE PRICE - AT DISTRIBUTOR'S SOLE DISCRETION - ARE THE EXCLUSIVE REMEDIES OF THE CONSUMER. IN NO EVENT WILL DISTRIBUTOR OR ITS MANUFACTURERS BE LIABLE FOR ANY INCIDENTAL, DIRECT, INDIRECT, SPECIAL, PUNITIVE OR CONSEQUENTIAL DAMAGES (SUCH AS, BUT NOT LIMITED TO, DAMAGES FOR LOSS OF PROFITS, BUSINESS, SAVINGS, DATA OR RECORDS) CAUSED BY THE USE, MISUSE OR INABILITY TO USE THE PRODUCT. EXCEPT AS STATED HEREIN, NO OTHER WARRANTIES SHALL APPLY. NOTWITHSTANDING THE FOREGOING, CONSUMER'S RECOVERY AGAINST DISTRIBUTOR SHALL NOT EXCEED THE PURCHASE PRICE OF THE PRODUCT SOLD BY DISTRIBUTOR. THIS WARRANTY SHALL NOT EXTEND TO ANYONE OTHER THAN THE ORIGINAL CONSUMER WHO PURCHASED THE PRODUCT AND IS NOT TRANSFERABLE.

Some countries, states or provinces do not allow the exclusion or limitation of incidental or consequential damages or allow limitations on warranties, so limitation or exclusions may not apply to you. This warranty gives you specific legal rights, and you may have other rights that vary from state to state or province to province. Contact your authorized retailer to determine if another warranty applies.